

Easy-Laser™

Measurement and Alignment Systems

Extruder measurement system 12-0193

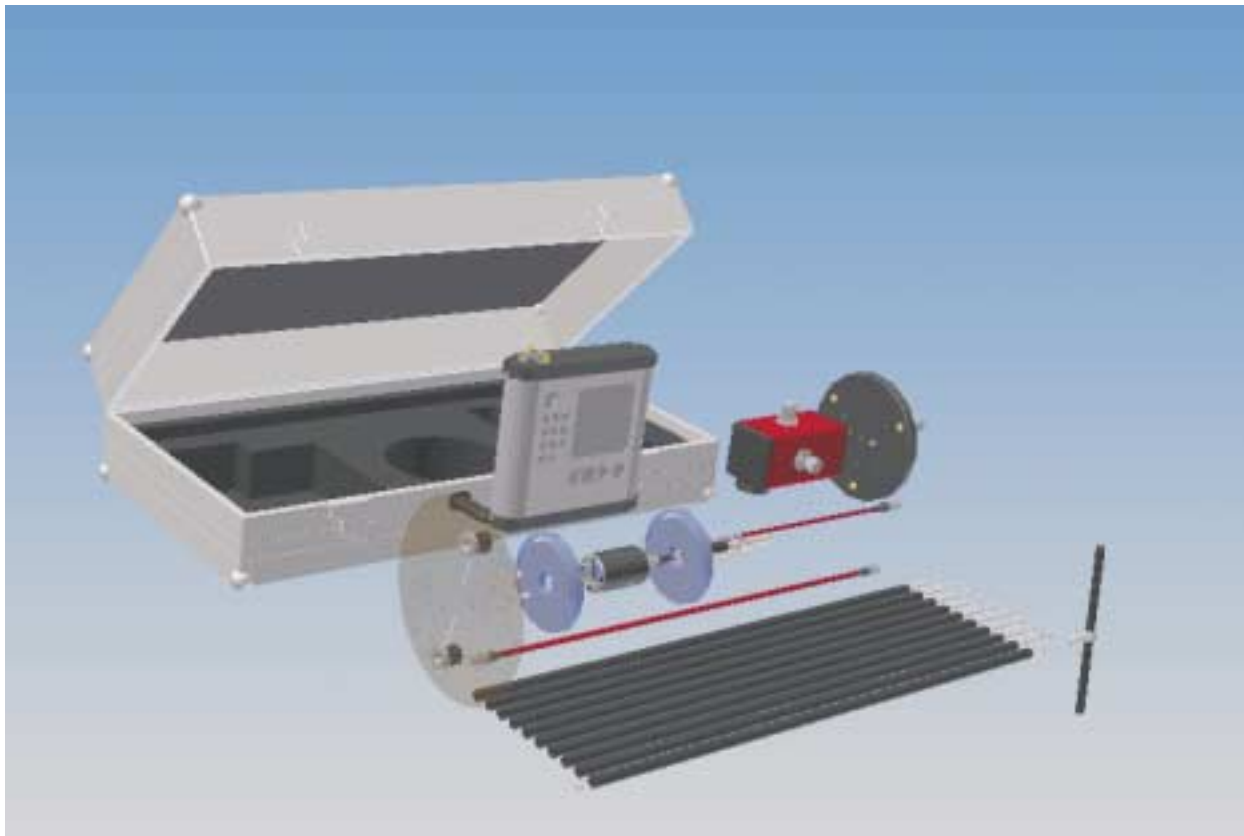

Technical data for the system extruder 12-0193

Min. tube diameter:	Ø40 mm.
Total length for the extension rod:	6 meter.
Detector measurement range:	app.15 mm [0,6"] vertically and horizontally.
Resolution of the measurement value:	Changeable down to 0,001 mm [0,05 mil]
Weight for the system in case	12 kg [26,5 lbs]:

Extruder alignment system

A badly aligned extruder plant leads to:

- too much tear on the extruder screw and tube
- uneven quality on the produced material
- higher energy consumption
- higher consumption of spare parts
- reduced availability on machine time

The alignment of an extruder plant can be divided up into 4 stages:

- Alignment of the transmission
- Alignment of the spindle centre of the gearbox compared to the centre of the extruder tube at inlet.
- Alignment of the spindle centre of the gearbox compared to the centre of the extruder tube at outlet.
- Straightness of the extruder tube

Alignment of the transmission

This is performed with Easy-Laser shaft alignment system, for example Easy-Laser D510 and on a beltdriven transmission it is performed with Easy-Laser BTA (belt transmission alignment system)

Alignment of the spindle of the gearbox compared to the centre line of the extruder tube and straightness on the extruder tube

This is performed with Easy-Laser extruder system which consists of: Lasertransmitter D75 with a magnet bracket which is placed at the end of the spindle of the gearbox + a detector with an adapter in plastic which is suitable for the diameter. With a extensionrod, which is mounted in the back of the detector, the detector can be slid in the whole length of the extruder tube. The result of both the spindle direction and the straightness of the tube is displayed.

Laser transmitter 12-0075

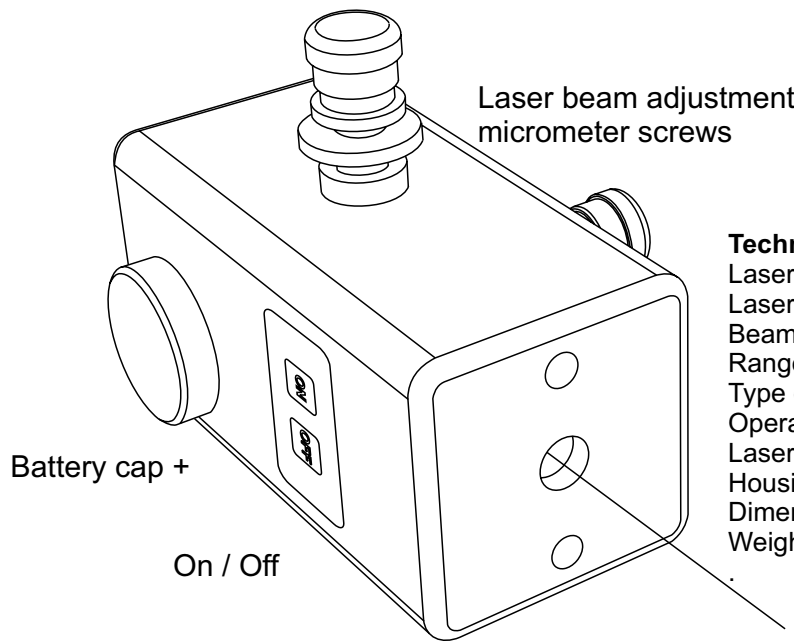

Technical specifications:

Laser diode	<1mW Class 2
Laser wavelength	635-670 nm
Beam diameter	6 mm at aperture
Range	100 feet [30 meter]
Type of battery	1 pcs. 1,5 Volt R14 ©
Operating time	>15 hrs
Laser adjustment	±2° (± 35 mm/meter)
Housing material	Anodized aluminum
Dimensions	60x60x120 mm
Weight	[700 g]
	SS-EN 60825-1-1994, CFR1040.10 och 1040.11

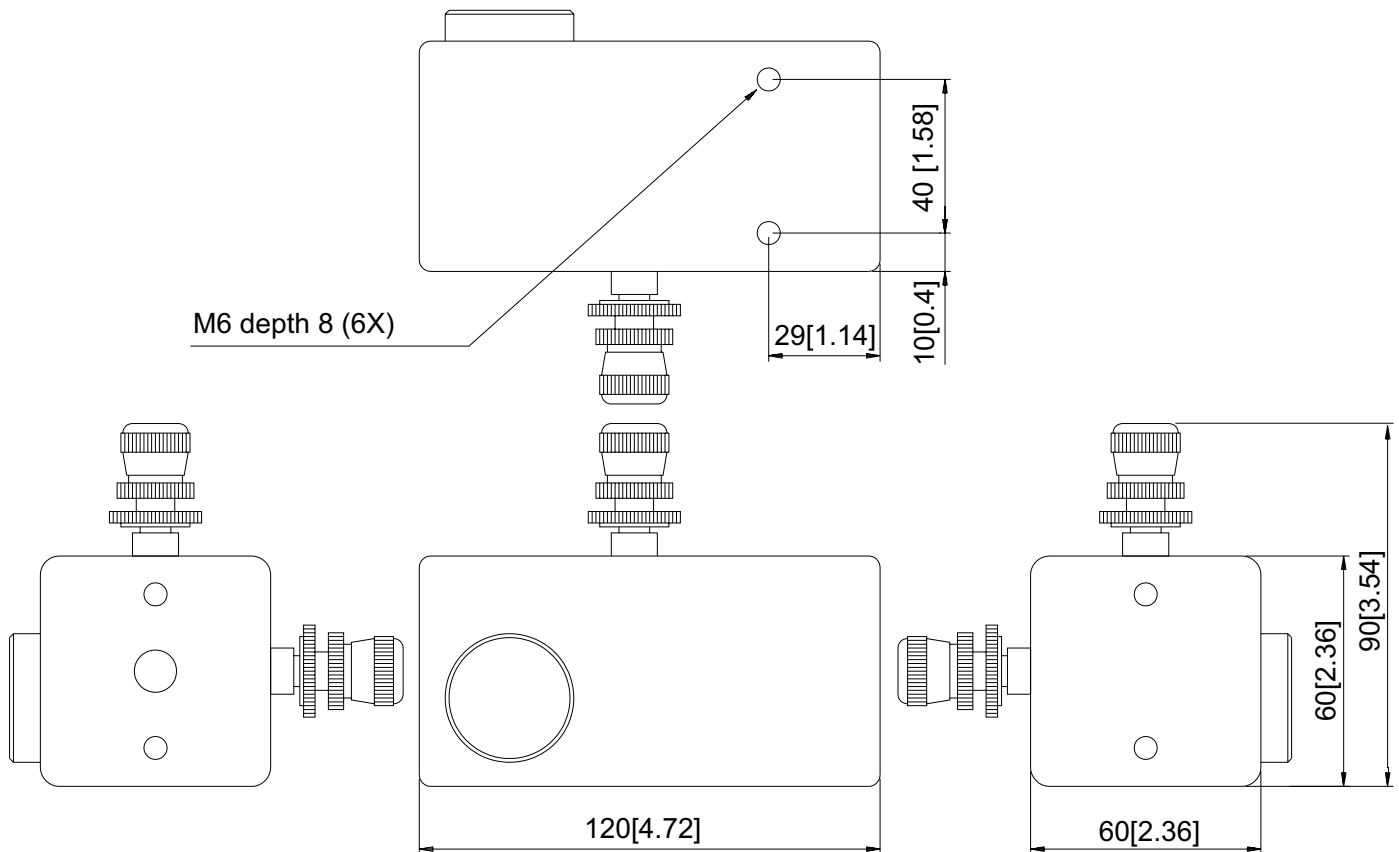
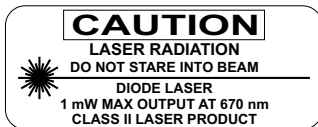

Detector 12-0157

Detector that reads the position of a laserbeam. Built-in 360° electronic inclinometer. A number of threads for different mounting possibilities. Two alternative connections for the display unit. Markings explaining measuring directions.

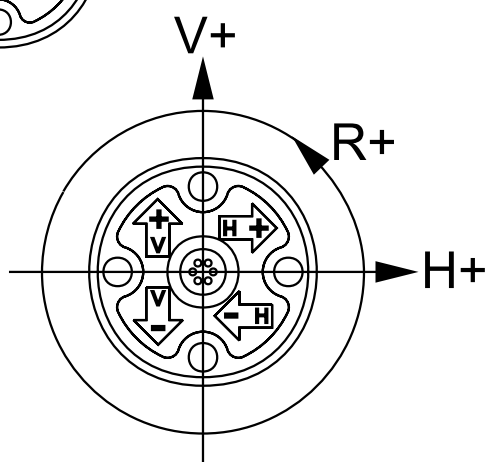
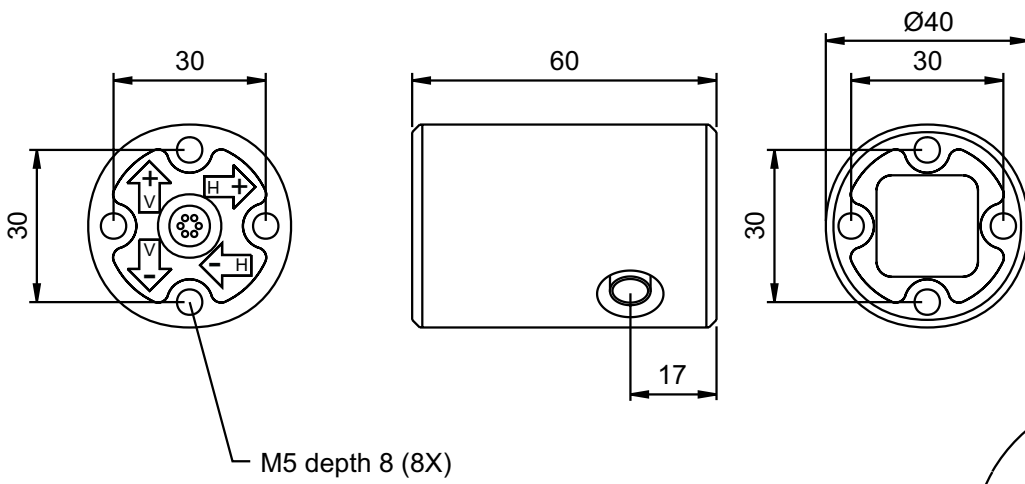
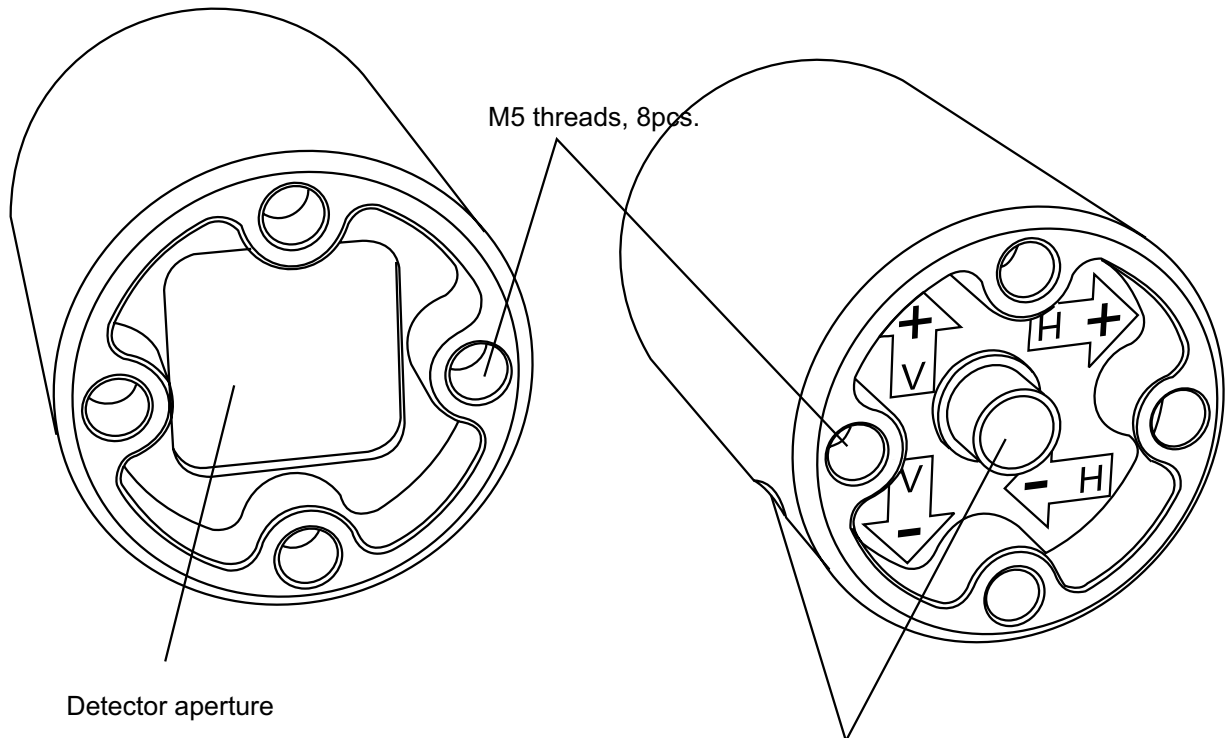

Technical Specifications:

Type of detector	2 axis PSD
Detector size	20x20 mm
Linearity	Better than 1%
Inclinometer resolution	0.1°
Dimensions	Ø1.57" L=2.36" [Ø40mm L=60 mm]
Housing material	Stainless steel, brass
Weight	7 oz [200 g]

When faced to the transmitter, moving the detector to the right will give positive H-values, and lifting upwards will give positive V-values. Rotation counterclockwise around a horizontal axis will give positive angular (R) values.

Display unit 12-0172

Battery operated unit with possibility to connect 10 measuring units/detectors in series connection. Membrane keyboard with 16 buttons and backlit LCD display. 20 universal programs for different measurement. Measurement data storage. Serial port for printer and PC communication. Delivered with leatherette case for rough environment.

Leatherette case with suspension belt.

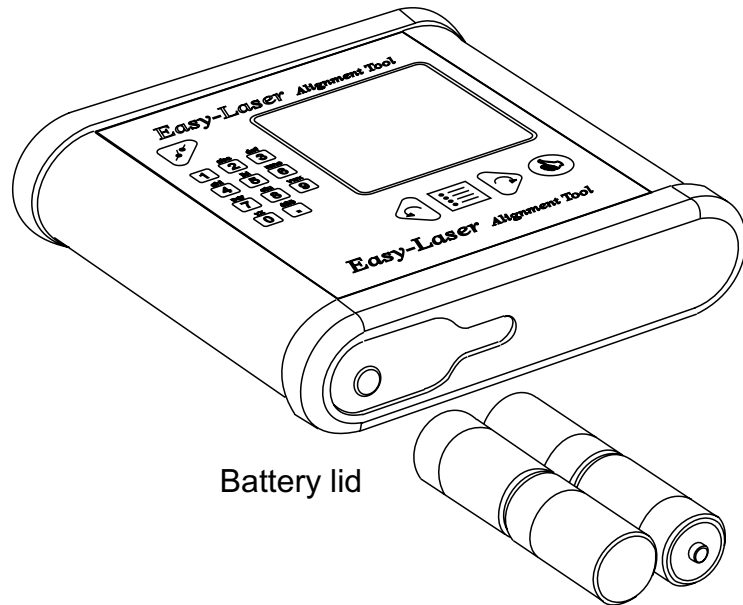
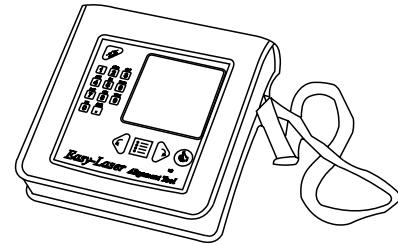

Serial port

Db9 Male

2 RxD
3 Txd
5 GND
7 RTS
8 CTS

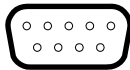

Battery lid

Technical specifications

Material	Aluminum / ABS
Keyboard	16 pcs. membrane
Display	Backlit 4.5" LCD
Battery type	4 pcs. .1.5 V R14 (C)
Operating time	48 hrs continuously 24 hrs with 2 measuring units connected
Displayed resolution	Changeable, down to 0.001 mm (0.05 mil)
Memory	Stores up to 125 shaft alignments or 600 measurement points
Connections	Serial port RS232, 9P
Dimensions	175x170x40 mm [7"x6x3/4"x1 1/2"]
Weight	1250 g [2.8 lbs]

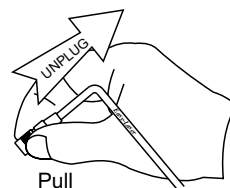
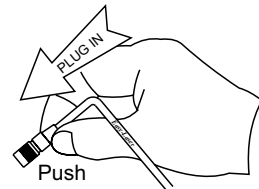

The connections between display unit and detectors should be connected as on the picture.

Target 12-0199

For rough alignment of the laser beam. Ø200 mm [8"] plastic. 2 magnets and concentric circles for alignment to the outlet of the tube.

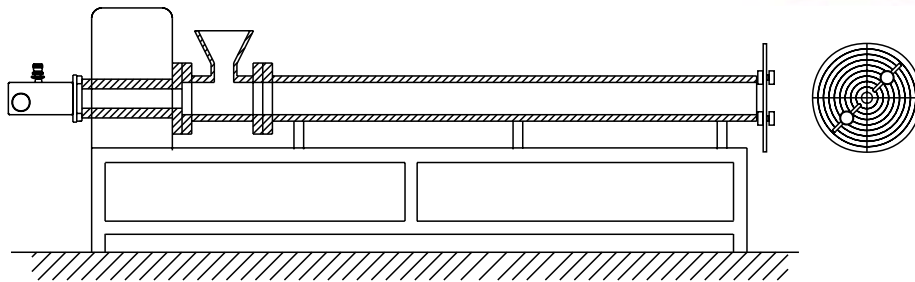

Adapter

Manufactured to fit in the tube and allows a deviation of ± 1 mm [± 0.04 "].

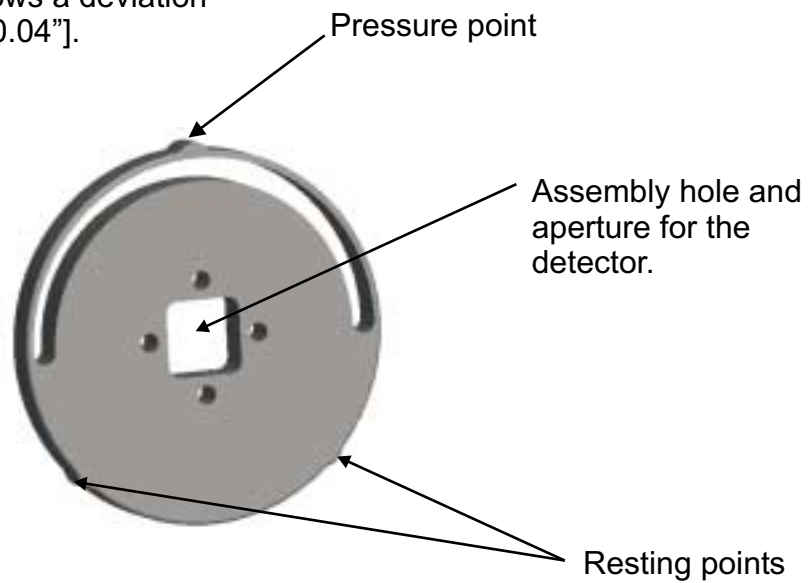

Assembly the parts

The laser 12-0075 and the magnet bracket 12-0187



The detector 12-0157 mounted at two adapters with 4+4 pcs. M5x16 screws, cable and cardan joint for the extension rods. The detector label facing the pressure points at the adapters.

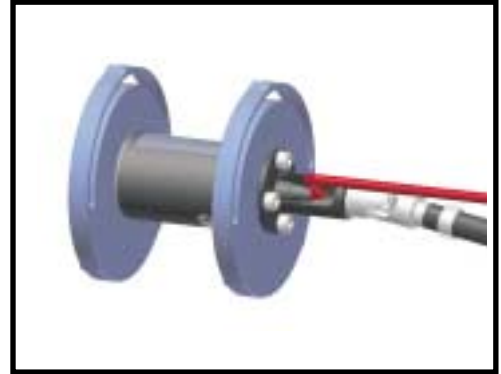

The laser and magnet bracket attached to the gearbox spindle.

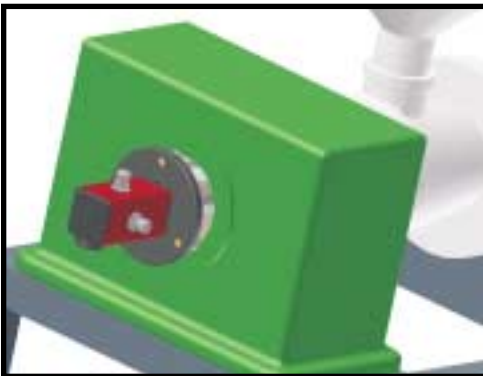

The detector with adapters in the outlet of the extruder tube.

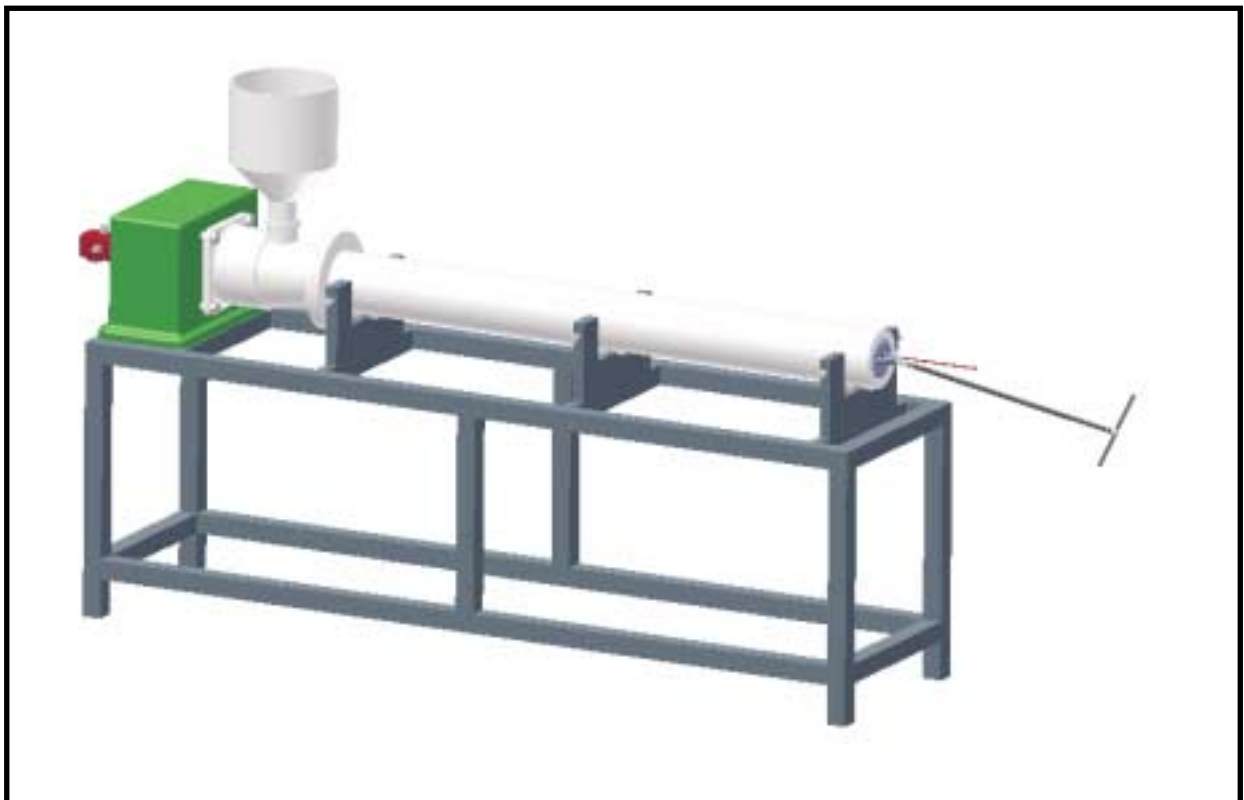
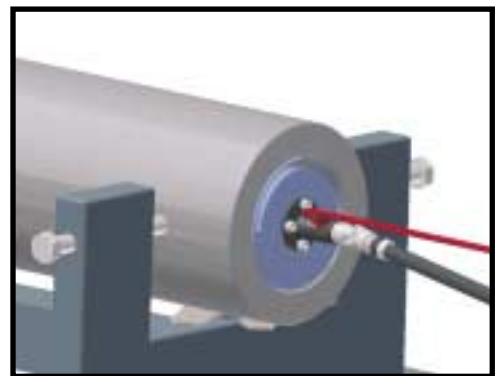

Alignment of the spindle of the gearbox compared to the centre line of the extruder tube

It is important that the centre line of the spindle coincide with the centre line of the extruder tube. Otherwise the screw at the inlet's end will be pressed against the tube, which will lead to abnormal tear of both screw and tube along with an increased energy consumption. This can also result in metal fragment in the produced material.

Since we during the alignment procedure rotate both detector and spindle we can read how the centre line of the spindle is compared to the tube's centre at the inlet end.

Normal is that gearbox and extruder tube is linked together and that it is easy to believe that the spindle's centre line always coincide with the tube's centre line. But experience show that is not always the case, depending on the fact that the gearbox due to its weight will bend in theirs connection and a parallel offset occur and the spindle's centre do not coincide with the centre line of the tube.

At unacceptable misalignment the connection has to be adjusted or shimmed.

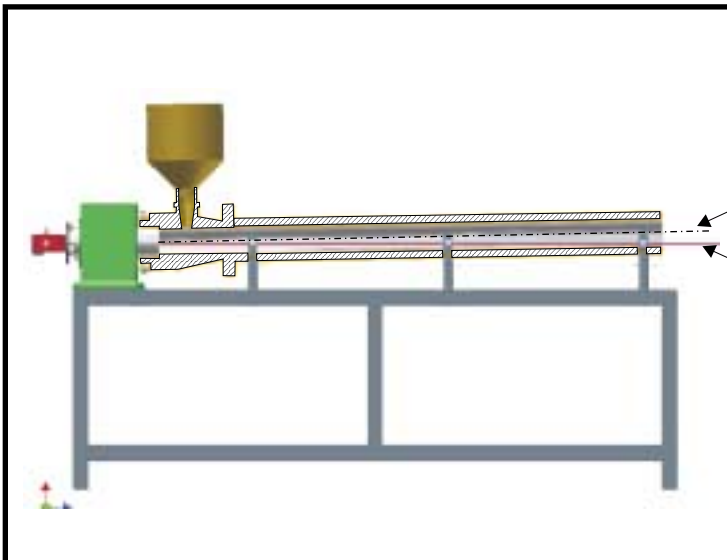

The centre line of the tube

The centre line of the gearbox spindle

Measurement procedure:

1. Mount the lasertransmitter at the end of the gearbox spindle.
2. Mount the target at the end of the tube and adjust it to the centre with the help of its concentric circles.
3. Adjust the laserbeam to the centre of the target with the micrometer screws.
4. Rotate the lasertransmitter to adjust the circle the beamdescribes to be as little as possible.
Remove the target and start program "Values".
5. Place the detector inside the tube at the inlet
6. Start the program "Values".
7. Turn the detector to R-value= $180^\circ \pm 1^\circ$.
8. Zero the values with .
9. Rotate the detector 180° to R-value $0^\circ \pm 1^\circ$.
10. Rotate the lasertransmitter 180° .
11. Half the values with .

Read the pointing direction of the gearbox compared to the inlet of the tube.
Record the value with 

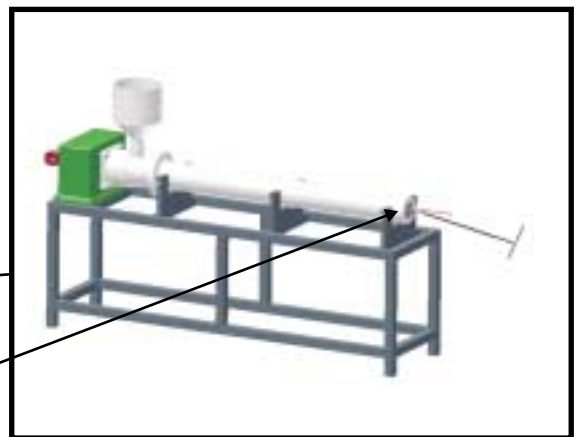
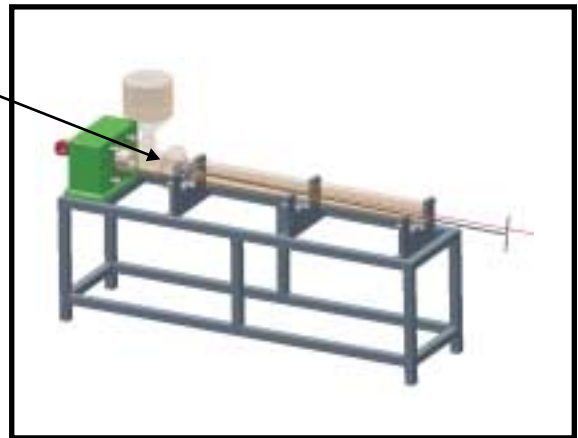

Record:	R 0.0
V 0.83	H 1.24
V 3.50	H 2.20
Units	1 Of 1

12. Rotate the detector half a turn, move it to the outlet of the tube and adjust the R-value to $180^\circ \pm 1^\circ$.
13. Repeat point 8-11 and read the pointing direction of the gearbox compared to the outlet of the tube.

Understand the measurement values when measuring the pointing direction of the gearbox spindle.

Record:	R 0.0
V 3.50	H 2.20
Units	1 Of 1

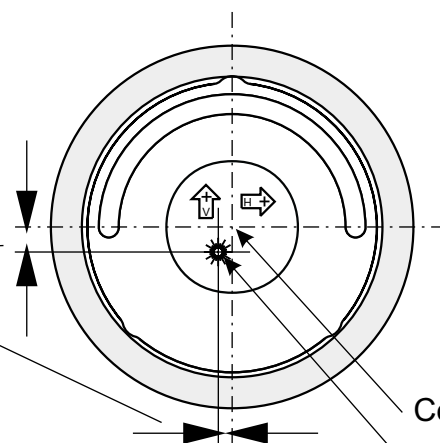

Centre of the tube
Pointing direction of the gearbox

Positive V-values mean that the gearbox is pointing downwards, and positive H-values mean that it is pointing to the left (seen from the detector).

The straightness of the extruder tube

It is important that the tube is straight so that the screw does not rest against the tube in any part, which also can result in abnormal tear and fragment of metal in produced material. If the tube is straight the screw can easier centre itself due to the forces in the produced material. We will also get a more even temperature of produced material which in the end also results in a better product.

Measurement procedure:

1. Decide the number of measuring points and the distance between them and enter requested data to the program.
2. Let the first measuring point be at the inlet of the tube, check the R-value ($0^\circ \pm 1^\circ$), and then record the value with .
3. Place the detector at the next (second) measuring point, check the R-value and record.
4. Continue with the other measuring points, then the result will be presented.

Example with 5 measuring points.

Toggle between table and graph with  and between H- and V-values with .

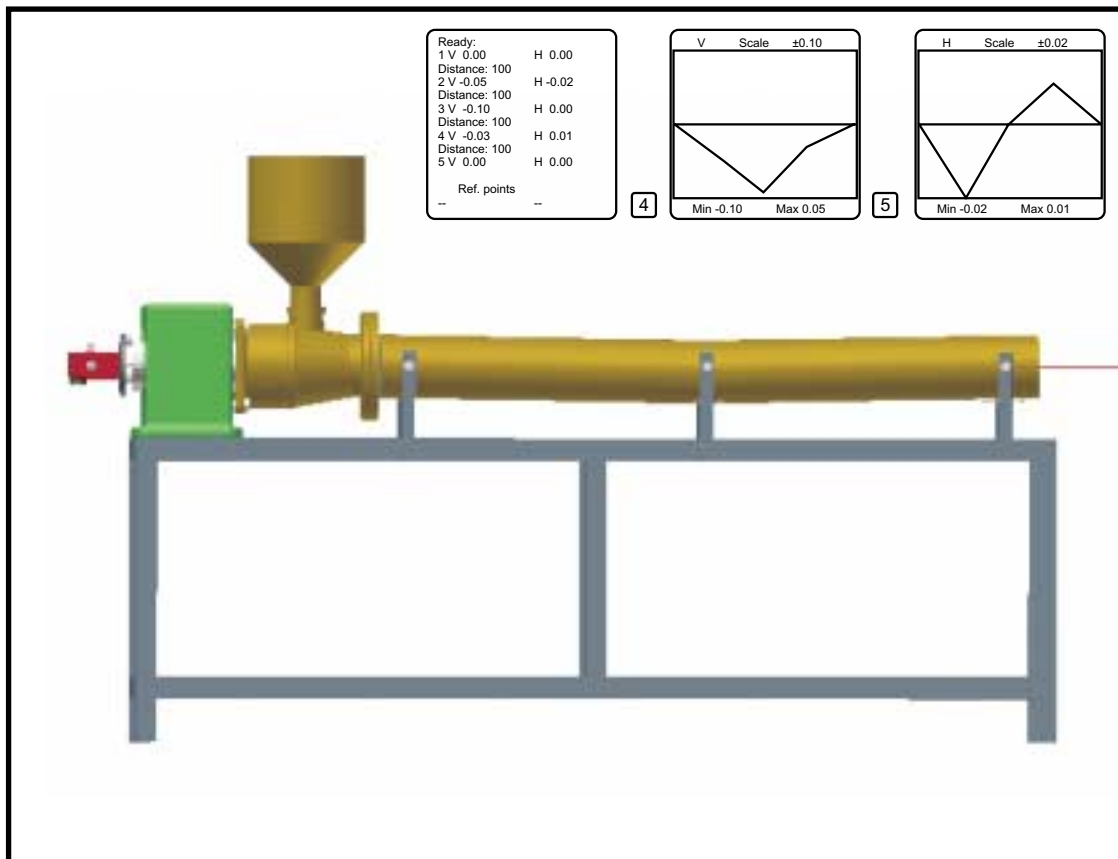

Damalini



Measurement And Alignment Technology

Damalini AB, Åbäcksgatan 6B, S-431 67 Mölndal, SWEDEN
Tel. +46 31 188770, Fax +46 31 188775
e-mail: easy-laser@damalini.se
www.damalini.com

05-0165 Rev2